

EV Charger Circuit Protection

IP66 Plastic Enclosure



Safety Warning

These instructions are intended for use by qualified electricians.

This unit must be installed by a qualified registered electrician in accordance with the current IET Wiring regulations BS7671.

Before commencing any electrical work ensure the electrical supply is isolated and securely locked off.

This Sync Energy Consumer Unit consists of a plastic enclosure, with an integral DIN rail onto which a main switch isolator or RCD is mounted along with MCB's/RCBO's, neutral and earth terminals and all connecting cables Sync Energy Consumer units / Enclosures are tested to BS EN 61439-3 standard, this tested standard verifies the safety requirements and performance of the devices installed within the unit.

Sync Energy Circuit protection enclosures have been type-tested and approved with BG Electrical circuit protection devices. When adding or replacing devices, only BG marked devices and accessories should be installed inside this enclosure.

IMPORTANT NOTE: A DC leakage fault in the vehicle may 'blind' a Type AC RCD and render it ineffective, never feed any EVSE from an upstream Type AC RCD.

1. The total load must not exceed the rating of the incoming isolator or any other limiting factor.

2. Ensure all connections are secure and terminal screws are tightened up to the supplied torque settings see below.

3. **DO NOT USE POWERTOOL SCREWDRIVERS ON ELECTRICAL CONNECTIONS.**

Installation Features

- IP66 ingress protection / IK07 impact rating.
- Lockable front cover - suitable for locks with shackle diameter no greater than 5mm.
- Removable DIN Rail - for easy first fix.
- Raised DIN rail for easier cable routing.
- Enclosure comes with a large selection of drill out cable entries on the rear, bottom and sides giving maximum flexibility for the installation.
- Combi-style screws for one tool installation.
- Backed out and retained terminal screws.



Terminal Torque Settings

Connection	PZNo.	(mm)	>1.5mm ² (Nm)	≤1.5mm ² (Nm)	(mm)
Terminal bars	M5	6.5	2	1.3	14
Main Switch	M7	9	3.5	2.3	14
MCB	M5	9	2	1.3	14
RCBO	M5	9	2Nm L2 1.2Nm L1/N1 out	1.3	14
RCD	M6	9.5	2.5	1.3	14
SPD	M5	9	2Nm L/- 1.2Nm PE/N	1.3	14
AFDD	M5	9	2Nm in/- 1.2Nm L/N out	1.3	14

Consumer Unit Dimension and Knock-outs

Consumer Unit	Height mm	Width mm	Depth mm
5 Module	218.4	166.4	114.6

Consumer Unit	Top	Bottom	Base	Sides
5 Module	/	3 x 29mm	1 x 37mm	2 x 29mm, 2 x 38mm

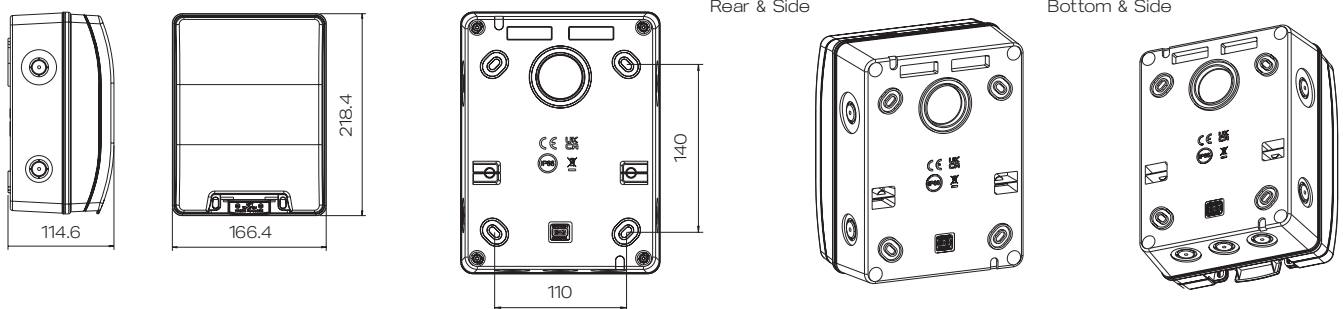

Installation

- Remove front cover by lifting up, quarter turn screws come in the open position. **NOTE:** Screws are captive and will not fall out.
- Provide cable access via either of the drill out cable entries in the sides (2 x 29mm or 2 x 38mm) bottom (3 x 29mm) or base (1 x 37mm) of the enclosure. For extra sealing protection, channels.
- around the knock-out and fixing holes are provided to accept a bead of sealant (not supplied) when fixing to mounting surface. Ensure IP rating is maintained e.g. use of glands.
- Secure to wall using the 4 fixing points, the holes are slotted to enable some rotation adjustment if required. Use appropriate wall fixings to suit the mounting surface. Fit supplied Bunges over all used fixing screw positions to seal aperture recesses.
- Fit any additional devices to the DIN rail if required, ensure cables are connected to the correct devices, neutral and earth terminals.
- Ensure all connections are secure and tightened to the correct torque setting (refer to torque table above or torque label in base of product).
- Test in accordance with the current IET wiring regulations.
- Fit cover blanks supplied if required.
- Refit front cover to base, secure using the quick fasteners. Turn 150° clockwise with a suitable Pozi bladed screwdriver to tighten, from to - **DO NOT OVER TIGHTEN.**
- Apply supplied SPD and identification labels to front cover above devices.
- Close front when not in use to maintain IP rating.

Accessories

Cover Blanks

Twist fit for any unused ways Sync Energy Code CUA01 Pk 10



Grommet Pack

To blank of fixing screw holes to maintain IP rating



Additional consumer unit accessories also available

Blank module 12 pk

DIN rail Mounted to fill any unused ways Sync Energy code - CUA19

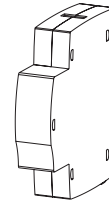

Interface Characteristics

Rated & Operational voltage (Un / Ue)	230V A.C 50Hz
Rated & Insulation voltage (Ui)	500V A.C 50Hz
Rated impulse withstand voltage (Uimp)	4kV
Rated current of the assembly (InA) Note: dependant upon rating of main incoming device	Main Switch 100A (marked rating of current on device) RCBO 40A (marked rating of current on device)
Rated current of an outgoing circuit (Ino)	RCBO 40A (marked rating of current on device) MCB 40A (marked rating of current on device)
Protection against electric shock	Consumer unit shall be installed in an electrical system conforming to the current edition of IEC 60364 / BS7671
Rated diversity factor (RDF) / Values of assumed loading	Note: RDF only applies to continuously and simultaneously loading circuits. In principle this means adjacent circuit breakers having a load 'on' time exceeding 30 minutes or where a load not exceeding 30 minutes has an 'off' time less than the 'on' time will need to have the rating diversity factor applied as indicated
Rated Frequency (fn)	50Hz
Pollution degree	3
Degree of protection	IP66 SUITABLE FOR EXTERNAL APPLICATIONS, NO INGRESS OF DUST AND POWERFUL WATER JETS FROM ANY DIRECTION
Electromagnetic compatibility (EMC) classification	A
External design	Wall-mounted, surface type, enclosed assembly
Mechanical impact protection	Enclosure IK07
The type of construction	Fixed parts
Type A DBO	Distribution board for use by ordinary persons

Contact Information

Sync Energy and BG Electrical are trading names of Luceco PLC

Luceco PLC
Stafford Park 1
Telford TF3 3BD
ENGLAND
(EU) Luceco SE
C/ Bobinadora 1-5
08302 Mataró
SPAIN

TECHNICAL SUPPORT

☎ + 44 (0)3300 249 279

✉ technical.support@bgelectrical.co.uk

🕒 08:30 to 17:00 (Monday - Thursday)
08:30 to 16:00 (Friday)

Care

To maintain the high quality appearance of this product Sync Energy recommend the use of a soft damp cloth periodically to clean the surfaces
ONLY CLEAN THE OUTSIDE OF THE CONSUMER UNIT

Batch Code Explanation

yyWxx: Manufacturing date code; year of manufacturing (yy) and week of manufacturing (Wxx)

Environmental Protection



This symbol is known as the 'Crossed-out Wheeled Bin Symbol'. When this symbol is marked on a product or battery. It means that should not be disposed of with your general household waste. Some chemicals contained within electrical/electronic products or batteries can be harmful to health and the environment. Only dispose of electrical/electronic/battery items in separate collection schemes, which cater for the recovery and recycling of materials contained within. Your co-operation is vital to ensure the success of these schemes and for the protection of the environment.

Consumer Unit and Devices Standards

The consumer unit and associated components are designed for use with copper cables and have been type tested to the below standards

Device/Component	Standard
Consumer Unit	BS EN 61439-3
Main Switch	EN/IEC 60947-3
RCD	EN/IEC 61008-1
MCB	EN/IEC 60898-1
RCBO	EN/IEC 61009-1
SPD	EN/IEC 61643-11
AFDD	EN/IEC 62606 & 61009-1
IP Rating	IP66

Guarantee

Sync Energy and BG Electrical Circuit protection products are guaranteed against faulty workmanship for a period of 10 years from date of delivery: products will be repaired or (at Sync Energy discretion) replacements will be supplied or (at Sync Energy discretion) a credit note will be issued. This guarantee is subject to Sync Energy conditions of sale and in particular to the following conditions being met:

1. Notification of any defect is given to Sync Energy as soon as reasonably practicable after becoming apparent, and the products then returned to Sync Energy.
2. The products have only been operated under normal operating conditions and have only been subject to normal use.
3. No work (other than normal and proper maintenance) has been carried out to the products without Sync Energy prior written consent.
4. The products have been assembled, or incorporated into other goods, by a qualified and recognised electrician and only in accordance with any instructions issued by Sync Energy.
5. The defect has not arisen from an item manufactured or supplied by a person other than Sync Energy.

This guarantee does not affect any consumer statutory rights. All components used in a Sync Energy enclosure, must be supplied by Sync Energy. The use of any other components will negate compliance to BS EN 61439 and the Sync Energy Guarantee. Failure to fit the enclosure in accordance with these instructions will invalidate the guarantee.